





amp ramp

Operators Manual

S2S Electronics Ltd

Turnbridge Mills

Quay Street

Huddersfield

West Yorkshire

HD1 6QT

Tel: 01484 530893

Fax: 01484 550500

Website: www.softstartdirect.com

Email: sales@softstartdirect.com

Issue 3 January 2003

Amp Ramp Specification

Mains Voltage	380/415V	
Mains Frequency	50/60Hz	
Control Voltage	Not required	
Parameter Adjustment	Pedestal Current	50 - 500% I
	Ramp Up Time	0.5 - 30 seconds
	Current Limit	100 - 500% I
LED Indication	Red	Ready
	Yellow	Ramping
	Orange	Current Limit
	Green	Full Speed
	Red Flashing	Drive rating exceeded
Relay Outputs	Top of Ramp - N/O Volt Free Contact 2A/100VA AC11 (110 - 240V)	
	Run-N/O Volt Free Contact 1A/50VA AC11 (110-240V)	
Overload Ratings	100% Continuous Current 300% Current for 30 seconds 500% Current for 5 seconds	
Starts per Hour	10 per hour evenly spaced, more possible by derating.	
CE Marking	CE marked to generic standards in accordance with BS EN 60947-4-2 using capacitive filter internally fitted.	
Heat Loss	4.5 Watts per Amp	
Cooling	Naturally cooled heatsink up to 30kW, fan cooled 37kW and above. Fan voltage 240V. All heatsinks mounted vertically. Allow 50mm around unit for cooling.	
Available Sizes	210SA-15	7.5-15kW Amp Ramp 31A rated
	210SA-22	22kW Amp Ramp 41A rated
	210SA-30	30kW Amp Ramp 56A rated
	210SA-37	37kW Amp Ramp 70A rated
	210SA-45	45kW Amp Ramp 85A rated
	210SA-55	55kW Amp Ramp 120A rated
	210SA-75	75kW Amp Ramp 145A rated
	210SA-90	90kW Amp Ramp 170A rated
210SA-110	110kW Amp Ramp 205A rated	
High Speed Fuses	Recommended for thyristor protection in the event of a short circuit see page 6 for more details.	

Amp Ramp Dimension Details

Amp Ramp Connections

15KW/22KW AMP RAMP

15KW/22KW
 DEPTH - 135mm
 MTG HOLE - Ø6.6
 WEIGHT - 5Kg

30KW
 DEPTH - 170mm
 MTG HOLE - Ø6.6
 WEIGHT - 8Kg

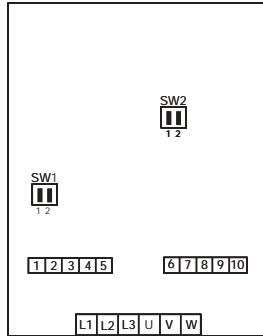
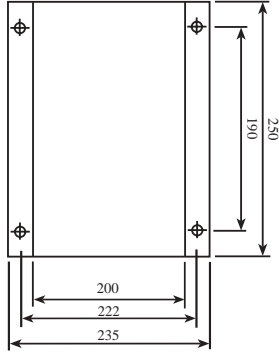

15KW AMP RAMP

L1 }
 L2 } MAINS SUPPLY
 L3 }

U }
 V } MOTOR SUPPLY
 W }

1 } START CONTACT
 2 }
 3 } NOT USED
 4 } CT INTERNALLY CONNECTED
 5 }
 6 } RUN CONTACT OUTPUT
 7 }
 8 } NOT USED
 9 } TOP OF RAMP CONTACT OUTPUT
 10 }

37-55KW AMP RAMP

DEPTH - 170mm
 MTG HOLE - Ø6.6
 WEIGHT - 9Kg

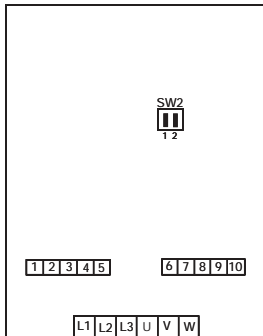
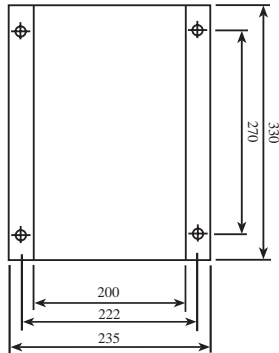

22 - 110KW AMP RAMP

L1 }
 L2 } MAINS SUPPLY
 L3 }

U }
 V } MOTOR SUPPLY
 W }

1 } START CONTACT
 2 }
 3 } NOT USED
 4 } CT INTERNALLY CONNECTED
 5 }
 6 } RUN CONTACT OUTPUT
 7 }
 8 } NOT USED
 9 } TOP OF RAMP CONTACT OUTPUT
 10 }

75 - 110KW AMP RAMP

DEPTH - 195mm
 MTG HOLE - Ø6.6
 WEIGHT - 17Kg

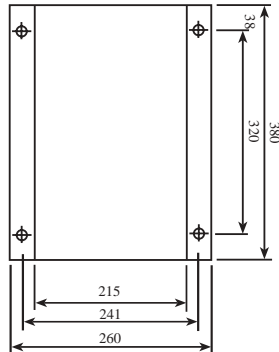

Fitting & Operating Instructions

SW2-1 Stop Delay

- Ensure unit is mounted vertically in a suitable dry, dust and vibration free enclosure, with connection terminals at the bottom.
- Electrical connections must be made as shown on drawings.
Phase rotation must be correct ie: L1, L2, L3 = R, Y, B.

If the soft starter is to be used with a by-pass contactor, SW2-1 should be set to the 'on' position. This will reduce contact burning by allowing the soft starter to break the current instead of the by-pass contactor.

SW2-2 Re-start Delay

This function prevents re-starting of the motor for a period of approximately 10 seconds. This is particularly desirable in the case of high inertia loads where the motor may continue to rotate at speed after the power is removed.

If a quick re-start is required, for example, in the case of a dual speed motor, the function may be disabled by setting SW2-2 to the 'on' position.

PLEASE NOTE IF PHASE ROTATION IS NOT CORRECT READY LED WILL NOT LIGHT AND UNIT WILL NOT FUNCTION.

- The unit should be used in conjunction with a suitably rated thermal overload to protect the motor and semiconductor fuses, to protect the thyristors.

Setting Up Switches

Please note, on Amp Ramp there are two switches that are relevant, and must be set by the user.

SW1: Fitted to 15kW Amp Ramps to select the motor kW

SW2: Fitted to Amp Ramps to set stop delay and re-start delay

Setting Up - Potentionmeters

Initial adjustments:

- Pedestal - Minimum
- Current Limit - Maximum
- Ramp Time - Maximum

Start the drive and increase the "pedestal" until the motor just starts to turn, i.e. sufficient torque is present to just overcome the stiction.

It may be necessary to start/stop the unit a few times to ensure the optimum setting.

Then reduce the ramp time to give the desired start period. With high inertia loads it may be necessary to limit the current using 'current limit' adjustment.

The time taken to reach full speed will then be affected by the current limit setting.

SW1:

Firstly the current feedback must be scaled by setting the selection switches placed above the terminals. The following table gives the switch settings for standard motor ratings. Please note this is only necessary on 15kW model, all other models are factory scaled for correct feedback.

		Switch Number	
		1	2
kW Rating	7.5	OFF	OFF
	11	ON	OFF
	15	ON	ON

Internal Protection of amp ramp

The amp ramp has internal protection circuits which will trip in the event of heatsink overtemperature and drive rating exceeded. This protects the amp ramp only and will not offer motor protection. In the event of a trip the red light will flash. Reset is activated through a powerdown sequence.

Typical Circuit Amp Ramp - No By-Pass

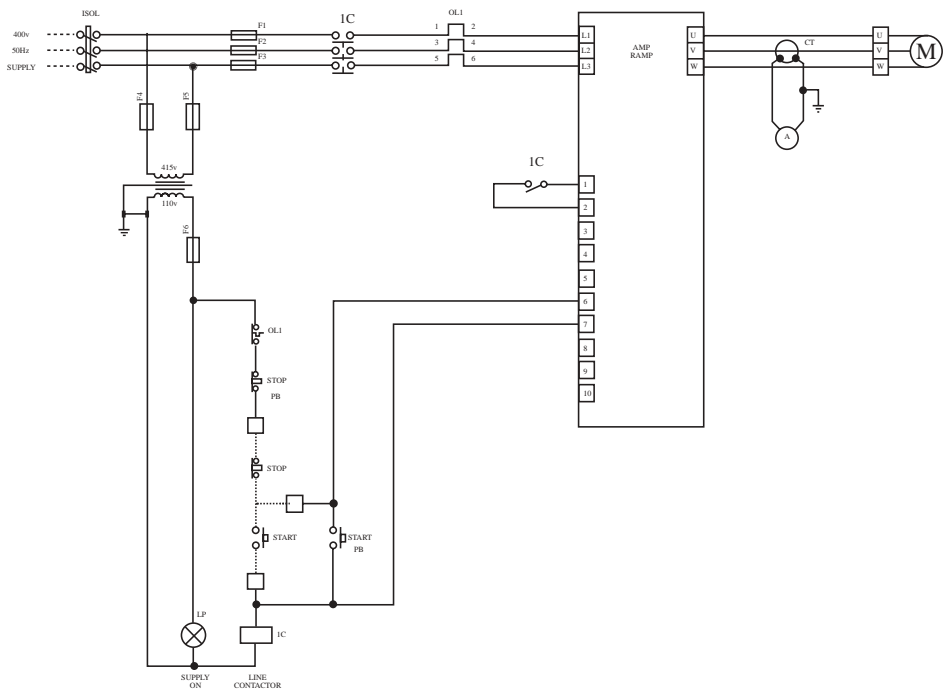

Typical Circuit Amp Ramp - with By-Pass

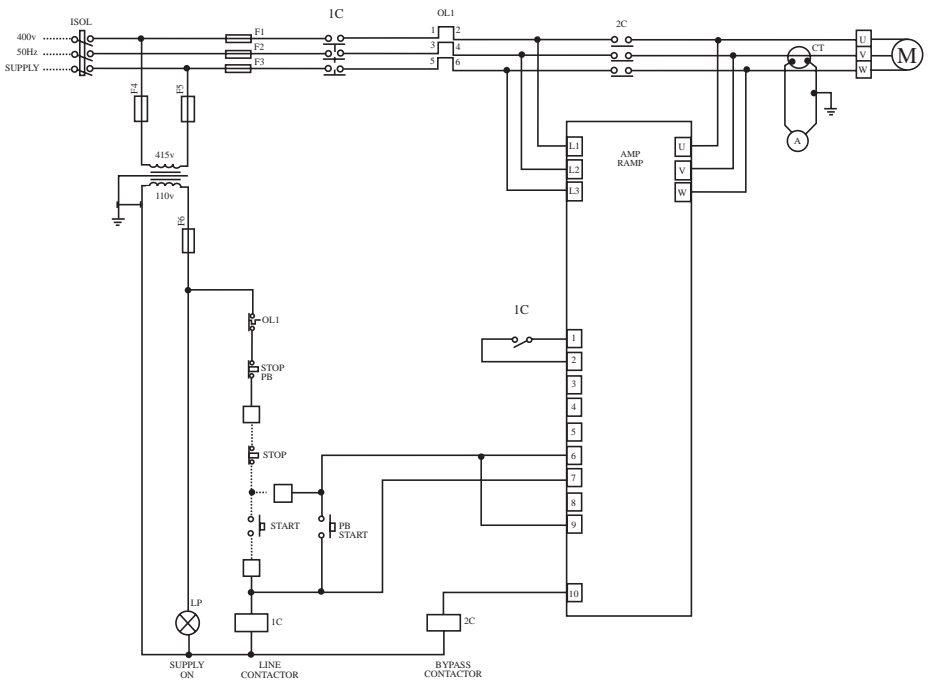

Emc and Amp Ramp

In order to achieve compliance with generic EMC standards in accordance with BS EN 60 947-4-2, it is necessary to fit a capacitive filter. These are internally fitted by safronics 2S Ltd.

Important Information:

1. When power factor correction capacitors are used, they must be connected on the supply side of the soft start and energised when the motor has reached full speed.
2. For applications where forward and reverse operation is required, the contactors **MUST** be wired in the output of the Amp Ramp as the units are phase sensitive.
3. Amp Ramp is fitted with Top of Ramp for energising by-pass contactors. Circuit Diagram for this is shown on page 4.
4. Please note, if changing a control card on Amp Ramp, the units are fitted with burden resistors to ensure correct feedback from internal CT's. Please ensure correct burden resistors are fitted to new control card.

Fuses for Amp/Ramp

High speed fuses are recommended for protection of thyristors and these are available in sets of three, supplied with fixings. The recommended fuse sizes are shown in the table below:

Fuses are supplied with the following fixing types:

DIN 43 653 size 0000 body	80A-100A
DIN 43 653 size 000 body	160A-315A
DIN 43 653 size 00 body	400A

Dimensions and fuse holder details are shown on page 6.

Soft Start Type	Fuse Product Code	Current Rating	Torque setting	Fuse Holder
210SA-15	170M0116	80A	4NM	170H1013
210SA-22	170M0117	100A	4NM	170H1013
210SA-30	170M1319	160A	4NM	170H1013
210SA-37	170M1319	160A	4NM	170H1013
210SA-45	170M1320	200A	4NM	170H1013
210SA-55	170M1321	250A	12NM	170H1007
210SA-75	170M1322	315A	12NM	170H1007
210SA-90	170M2621	400A	12NM	170H1007
210SA-110	170M2621	400A	12NM	170H1007

Fuse Dimensions

50/200AMP FUSE

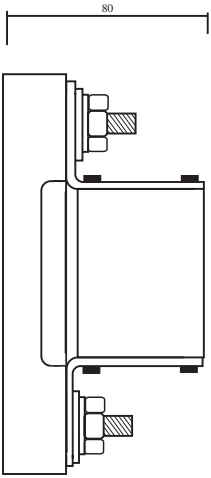

200-400AMP FUSE

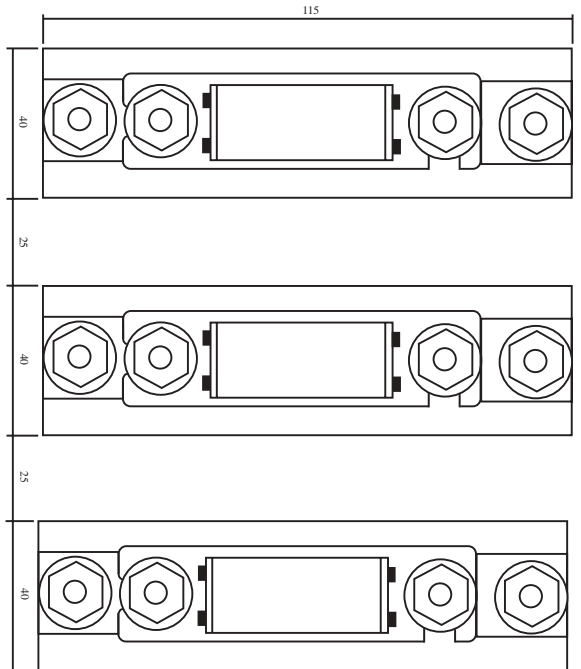
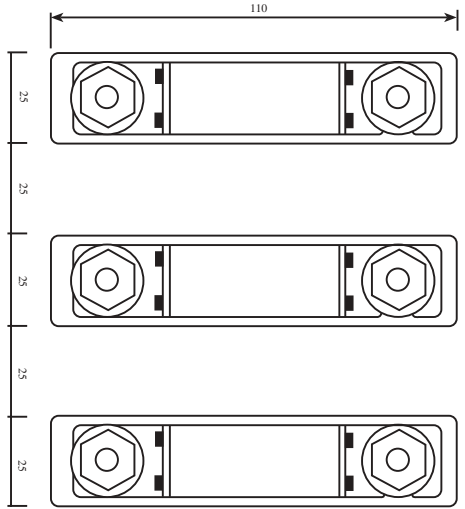
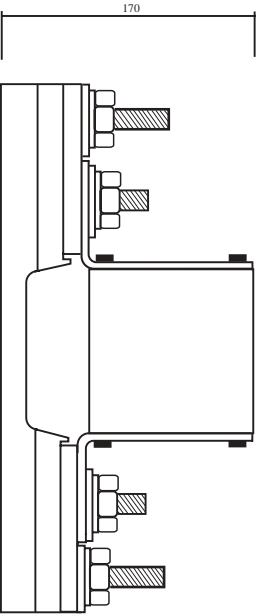

Issue Numbers

Issue	Description/Modification	Date	Modified	Checked
1	Initial issue	March 00	-	AD
2	All pages - Reference to 4kw Amp Ramp Removed	2/4/01	AD	SM
3	References to new frame sizes	15/1/03	AD	SM